

Stolpestøtte Til nedstøbning



ETA-10/0153



Materiale: S235JRG
 Iht.: EN 10346
 Overfladebehandling: Varmforzinket ca. 55 µm
 Anvendelsesklasse: 1 - 2 - 3

Måltegning:

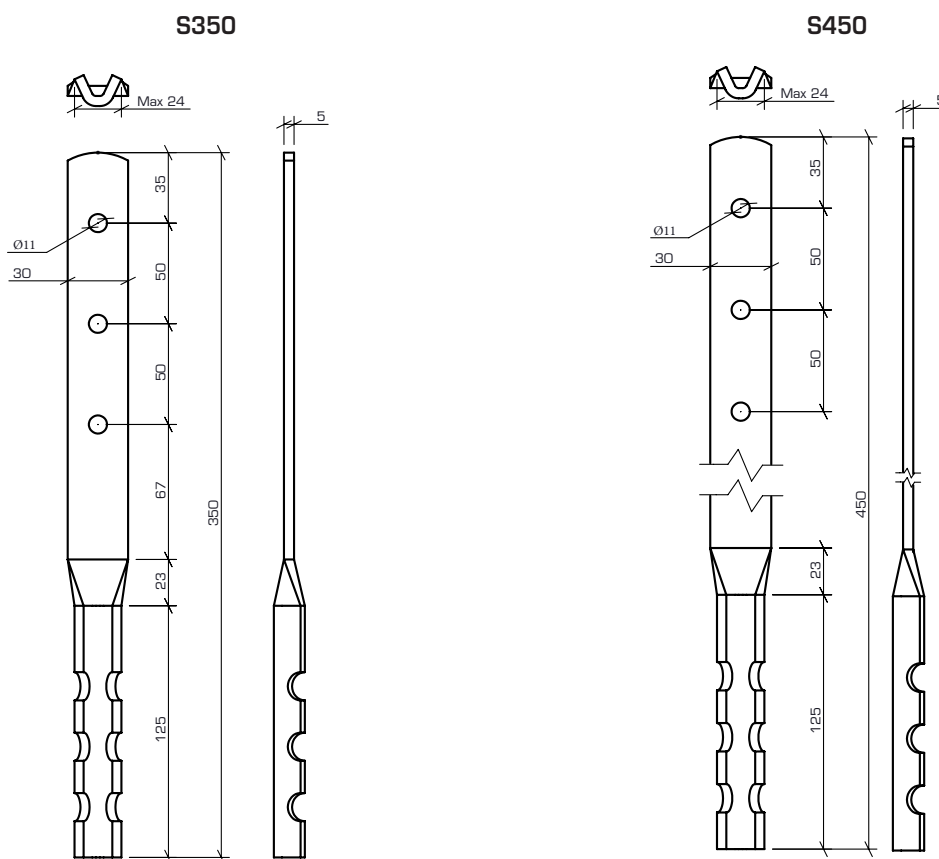

Type	Dim. H x B x t [mm]	Huller Ø11 [antal]	Vekt [Kg]	Antall pr. pk	Antall pr. pall	Motek nr.
S350	350 x 30 x 5	3	0,410	10	500	
S450	450 x 30 x 5	4	0,525	10	500	15730450

Stolpestøtte Til nedstøbning

Regningsmæssig bæreevne i kN pr. samling:

Normal sikkerhedsklasse - Anvendelsesklasse 1, 2 og 3

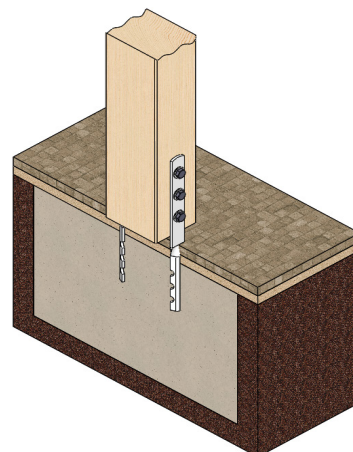

Stolpestøtte 2 stk. S350

Bolte [Boltplacering placering]	Antal Bolte	Lastgruppe	F1↓ SC1+2 [kN]	F1↓ SC3 [kN]	F1↓ Stål [kN]	F1↓ SC1+2 [kN]	F1↓ SC3 [kN]	F1↓ Stål [kN]
	• 2 x 3	Kar.	4,51	4,51		4,51	4,51	
		P-last	2,00	1,67		2,00	1,67	
		L-last	2,34	1,84	16,86	2,34	1,84	33,66
		M-last	2,67	2,17		2,67	2,17	
		S-last	3,01	2,34		3,01	2,34	
		H-last	3,67	3,01		3,67	3,01	

Stolpestøtte 2 stk. S450

Bolte [Boltplacering placering]	Antal Bolte	Lastgruppe	F1↓ SC1+2 [kN]	F1↓ SC3 [kN]	F1↓ Stål [kN]	F1↓ SC1+2 [kN]	F1↓ SC3 [kN]	F1↓ Stål [kN]
	• 2 x 3	Kar.	4,51	4,51		4,51	4,51	
		P-last	2,00	1,67		2,00	1,67	
		L-last	2,34	1,84	4,95	2,34	1,84	33,66
		M-last	2,67	2,17		2,67	2,17	
		S-last	3,01	2,34		3,01	2,34	
		H-last	3,67	3,01		3,67	3,01	

Stolpestøtte Til nedstøbning

Anvendelse:

- * Fastgørelse af træstolpe til nedstøbning i beton.
- * Anvend altid 2 stk. pr. samling.

Anvendelse	
 A technical illustration showing a wooden post being secured to a concrete slab. The post is shown in a cross-section, with two metal brackets (one on each side) being inserted into pre-drilled holes in the concrete. The brackets have a serrated edge that fits into the hole, and they are secured with screws. The concrete slab is shown in a cross-section, with a top layer of brickwork and a bottom layer of soil. The wooden post is shown in a cross-section, with a top layer of wood and a bottom layer of wood. The metal brackets are shown in a cross-section, with a serrated edge and a hole for a screw.	

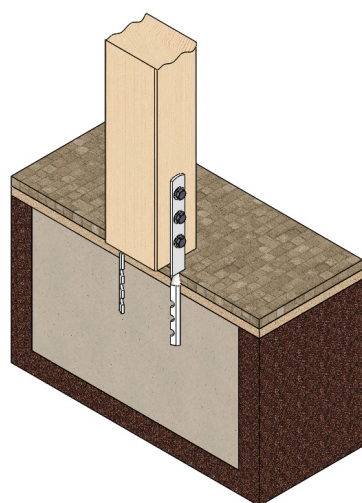

Stolpestøtte generelt:

- * Varmforzinket stål med 55 μm for lang holdbarhed.
- * Til udendørs brug.